



GLOBAL  
FINISHING  
SOLUTIONS

# AUTO REFINISH PRODUCT CATALOG





# TABLE OF CONTENTS

About GFS .....	4
Long-Lasting Construction .....	5
Ultra Paint Booths .....	6-17
Performer Paint Booths .....	18-22
Ultra CTOFs.....	23-27
Excel Workstations.....	28-29
Aluminum Repair.....	30-31
Ultra Paint Mix Rooms .....	32-34
GUL2000 Air Heater .....	35
BT1200 Air Heater.....	36
SpaceSaver Air Heater .....	37
REVO Accelerated Curing Systems.....	38-39
AdvanceCure Systems.....	40-41
Control Panels .....	42
Control Features.....	43
GFS Airflow .....	44
Exhaust Pits .....	45
Booth Lighting.....	46
Booth Accessories.....	47

# ABOUT **GFS**

## IN-HOUSE MANUFACTURING

Global Finishing Solutions' products are designed and manufactured in our Osseo, Wisconsin, facility. With more than 200,000 square feet of manufacturing space and state-of-the-art equipment, GFS has the capability and talent to build our equipment from scratch. Virtually every part of our product line is built in-house, including the enclosures, control panels, ductwork and light fixtures.



## RECOGNIZED QUALITY

When you invest in capital equipment, you want a reliable, proven product from a company you can count on. Global Finishing Solutions is experienced at designing and building state-of-the-art paint booths and finishing equipment that exceed our customers' expectations. Body shops and collision centers of all sizes continue to come back to GFS for consistent, quality equipment every time.

## RESEARCH & DEVELOPMENT

Dedicated to continuous improvement and developing industry-leading products and technology, GFS invested in the Center for Excellence, a state-of-the-art facility for research, development and training. The Center for Excellence allows GFS to complete rigorous validation processes, ensuring that our products meet quality, budget and time frame requirements.

## CODE COMPLIANCE

GFS manufactures and designs paint booths and finishing equipment to meet applicable industry codes and standards. Please be aware that local requirements may vary from national codes. GFS recommends consulting local authorities before purchasing paint booths or finishing equipment.

- Reference NFPA 33 and Chapter 24 of the International Fire Code (IFC) for spray applications using flammable and combustible materials
- Reference NFPA 86 and Chapter 30 of the IFC for curing and drying applications
- Many components and product lines are ETL and ETL-C listed. The ETL or ETL-C mark is proof of compliance with North American safety standards, including UL, NFPA, OSHA and more
- A UL or CUL listing verifies that Underwriters Laboratories has tested GFS' product and determined that it meets their stringent safety and performance requirements



## GFS SPECIFICATION & COMPONENT DISCLAIMER

All designs, specifications and components are subject to change at the manufacturer's sole discretion at any time without notice. Data published herein is informative in nature and shall not be construed to warrant suitability of the unit for any particular purpose as performance may vary with the conditions encountered.

# LONG-LASTING CONSTRUCTION

## VERTICAL WALL PANELS

All GFS auto refinish booths feature vertical wall panels that are designed to reduce the number of joints and seams in the cabin's construction. With fewer joints, you are left with a stronger, longer-lasting booth. Fewer seams allow for smoother interior walls, which are less likely to collect contaminants and overspray, making them easier to clean.

GFS' auto refinish booth panels are made of sheet or coil steel that is primed and coated on both sides with a baked-on polyester topcoat for a rust-resistant cabin in even the harshest of environments. To protect booth panels during installation, a PVC protective plastic sheeting is applied before shipping. This plastic is easily removed once installation is complete.

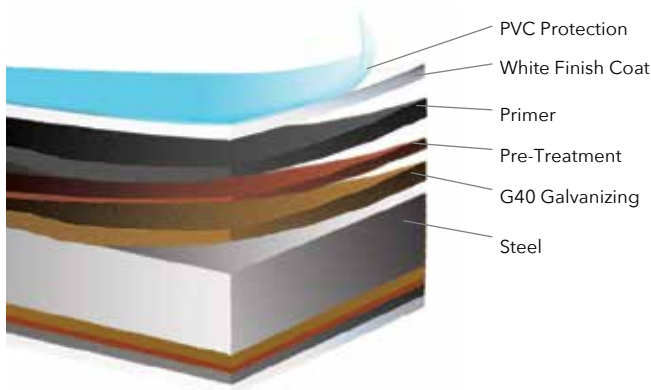

## TOP-QUALITY HARDWARE

GFS uses high-quality hardware – including heavy-duty latches, long-lasting brass bushings, durable hollow rubber seals and sturdy handles – to ensure ease of use and many years of reliable service. Hinges and latches stay secured and are fully adjustable for a perfect fit. Our weld-free designs prevent against weak points and corrosion, making for a sturdy, long-lasting booth.



## DUAL-SKIN PANELS

Pre-coated, dual-skin insulated panels provide a smooth fit and finish with no exposed wires or cables. Two 20-gauge pieces of fully insulated sheet steel cut down on noise and keep heated air inside the cabin. For easier booth setup, 6-inch galvanized steel H-channel columns connect wall panels without the need for nuts and bolts. Because panels come together with a positive, virtually airtight seal, there is less potential for contamination.



## SINGLE-SKIN PANELS

Single-skin, precision punched panels are made from 18-gauge coil steel that is roll-formed into an H-style panel. Nut-and-bolt construction provides unmatched strength and rigidity, while the exterior flanges on paint booths create a smooth surface and easier cleaning on the booth's interior walls.



# ULTRA<sup>®</sup> PAINT BOOTHS

GFS' premium Ultra Paint Booths provide the highest-quality solution for painting automotive vehicles and parts. With exceptional lighting, intuitive controls, premium contamination control and effective overspray capture, high-performance Ultra Booths allow for flawless paint finishes and increased productivity.

Pre-engineered Ultra Paint Booth models and standard options are fully ETL and ETL-C listed, ensuring that the entire booth complies with applicable safety codes and meets performance requirements. ETL listing facilitates successful inspections and demonstrates that Ultra Booths have completed independent, third-party review.



## HIGH-PERFORMANCE AIRFLOW

### DOWNDRAFT

Generally accepted as the best airflow style, downdraft booths do an excellent job of controlling overspray and contamination. Air enters downdraft Ultra Paint Booths through GFS' patented Controlled Airflow Ceiling, a full-width filtered ceiling plenum. From there, air flows vertically over the vehicle or part and into the filtered exhaust pit in the floor.

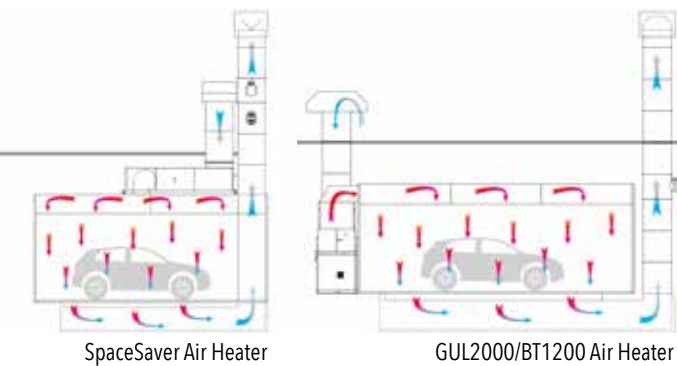

### SEMI-DOWNDRAFT

The semi-downdraft booth is a hybrid, combining features of both crossdraft and downdraft booths. Air is introduced into semi-downdraft Ultra Booths through the High-Performance Airflow Ceiling in the first 25-30 percent of the booth. It is then pulled through the working chamber, over the vehicle or part and into the filtered exhaust chamber at the rear of the booth.

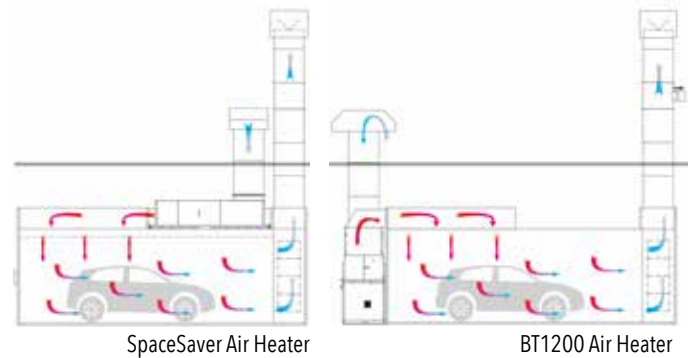

**Note:** Conceptual airflow representation, actual air heater layout may vary.

# ULTRA<sup>®</sup> MATRIX

S - STANDARD

O - OPTION

N/A - NOT AVAILABLE

FEATURES		ULTRA XP1	ULTRA XD	ULTRA XS	ULTRA XL
Airflow & Ceiling Type	Downdraft (Controlled Airflow Ceiling)	S	S	S	S
	Semi-Downdraft (High-Performance Airflow Ceiling)	N/A	S	S	N/A
Exhaust System	Pit (downdraft models only)	S	S	S	S
	Raised Basement (downdraft models only)	O	O	O	O
	Filtered Exhaust Yoke (semi-downdraft models only)	N/A	S	S	N/A
Controls	LOGIC 4 (with SmartFlash, SmartCure and Economy Mode)	S	O	O	O
	LOGIC 3 (with SmartFlash, SmartCure and Economy Mode)	N/A	O	O	O
	Engage (with Economy Mode)	N/A	S	S	S
Cure	Integrated AdvanceCure Blade System	S	O	O	O
	Ready to Integrate with AdvanceCure (Blades/Nozzles not included)	N/A	S	S	S
Air Heater	GUL2000 (downdraft models only)	S	S	S	S
	BT1200	N/A	S	S	S
	SpaceSaver	N/A	S	S	N/A
Lighting	Six-Tube, T8 LED Light Fixtures	S	O	O	O
	Four-Tube, T8 LED Light Fixtures	N/A	S	S	S
	Additional Sidewall Light Fixtures	O	O	O	O
Construction	Dual-Skin Insulated Panels	S	S	N/A	S
	Single-Skin Panels	N/A	N/A	S	S
	9-Foot-High Ceiling	S	S	S	N/A
	12-Foot-High Ceiling	N/A	N/A	N/A	S
	Floor Leveling System	S	S	S	S
Doors	Personnel Door	S	S	S	S
	Four-Wing Product Door	S	O	O	S
	Three-Wing Product Door	N/A	S	S	N/A
	Drive-Thru Configuration	O	O	O	O

# FULLY-LOADED **ULTRA**<sup>®</sup> XPI1

GFS' top-of-the-line booth, the Ultra XPI1 exceeds the automotive industry's standards for a premium paint booth. Incorporated into this booth is virtually every feature that sets GFS booths apart from the rest. No other spray booth can match the Ultra XPI1's level of production capability, performance, brightness, contamination control, ease of operation and energy efficiency.

## BOOTH FEATURES

### AIRFLOW & CONTAMINATION CONTROL

With a unique 14-foot-wide ceiling plenum, GFS' patented Controlled Airflow Ceiling increases the booth's spray zone. The main airflow zone in the Controlled Airflow Ceiling creates a protective envelope of air around the vehicle, while secondary airflow zones protect booth walls from overspray and keep contaminants out of the paint job.

### LIGHTING

Ultra XPI1 Booths feature six-tube sidewall light fixtures and premium angled ceiling light fixtures, integrated into the Controlled Airflow Ceiling and located directly above the vehicle for optimal illumination. Light fixtures are ETL and ETL-C listed, and come complete with T8 ballasts and LED lamps.

### CONTROL PANEL

With a touch screen interface, energy-saving settings, spray temperature and booth mode monitoring, booth balancing and self diagnostics, the LOGIC 4 control panel provides complete control over the Ultra XPI1 Paint Booth.

### FLASHING & CURING

SmartFlash and SmartCure<sup>®</sup> technology enables users to create up to three SmartFlash and six SmartCure profiles to set up booth cycles to quickly cure coatings. Ultra XPI1 Paint Booths also include integrated AdvanceCure Blade<sup>®</sup> Systems, which use turbulent airflow to cut cure times in half, saving time and energy.

### ENERGY SAVINGS

Shops can save up to 60 percent in electricity and 75 percent in fuel costs with economy mode, which automatically ramps the booth down and runs on idle when the booth is not in use. Providing further energy savings, SmartFlash allows up to 90 percent of the air to be recirculated during flash mode.

### BOOTH CONSTRUCTION

Manufactured at our U.S. facility, Ultra XPI1 Booths are constructed with white pre-coated sheet steel that is coated with a baked-on polyester topcoat for a rust-resistant cabin. Vertical wall panels and dual-skin construction create a smooth fit and finish.

### MORE BOOTH FEATURES

- Two-row pit
- Four-wing, dual-skin product door
- Personnel door
- Upgraded GUL2000 air heater
- Floor leveling system

### BOOTH OPTIONS

- Drive-thru configuration
- Three-row pit upgrade
- Raised basement (adds 13 inches to the overall height of the booth)
- Additional sidewall light fixtures
- Sidewall observation windows





Airflow	Inside Dimensions			Outside Dimensions*			No. of Light Fixtures		Product Door Opening	Air Heater	Dual-Row Pit Length
	Width	Height	Length	Width	Height	Length	Ceiling	Sidewall			
Downdraft	14'	9'	27'	14' 5"	11'	27' 5"	8	6	10' 8" W x 8' 8" H	GUL	24'
	14'	9'	30'	14' 5"	11'	30' 5"	10	6	10' 8" W x 8' 8" H	GUL	27'

\*Floor-mounted air heater dimensions are not included in the outside dimensions. Additionally, if a floor leveling system is used, booth height may increase beyond the dimensions listed.

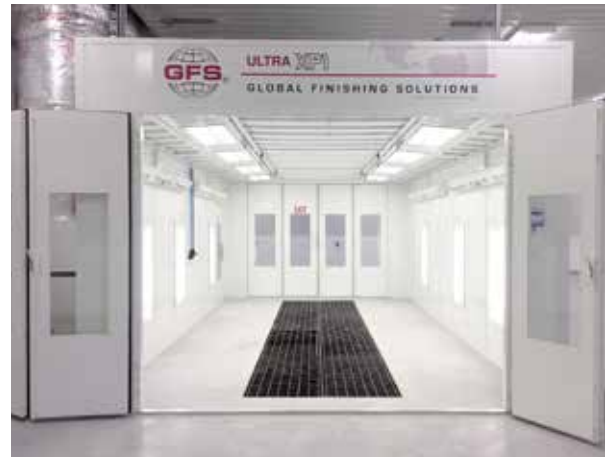

# VERSATILE ULTRA® XD

The Ultra XD Paint Booth leads the industry in versatility and performance. With a choice of high-efficiency heat systems, intuitive control panels, and downdraft or semi-downdraft airflow – along with superior lighting and contamination control – the Ultra XD will exceed any shop's expectations.

## BOOTH FEATURES

### AIRFLOW & CONTAMINATION CONTROL

Ultra XD Paint Booths come standard with GFS' patented Controlled Airflow Ceiling (in downdraft models) or the High-Performance Airflow Ceiling (in semi-downdraft models). Both ceilings allow for even distribution of air throughout the booth, providing excellent air filtration and precise contamination control.

### LIGHTING

Designed for optimal brightness, Ultra XD Booths feature four-tube sidewall light fixtures and either premium angled ceiling light fixtures (integrated into the Controlled Airflow Ceiling) or hip lights (with the High-Performance Airflow Ceiling). All GFS light fixtures are ETL and ETL-C listed, and come complete with T8 ballasts and LED lamps.

### CONTROL PANEL

The Ultra XD comes standard with an easy-to-use Engage control panel. Enhancements such as a touch screen interface, energy-saving settings, pressure control and alarm tracking allow for better, more reliable booth performance. Upgrading to the LOGIC 3 or LOGIC 4 control panel provides additional functionality and user-programmable features such as SmartFlash and SmartCure profiles.



### ENERGY SAVINGS

Shops can save up to 60 percent in electricity and 75 percent in fuel costs with economy mode, which automatically ramps the booth down and runs on idle when the booth is not in use. Providing further energy savings, SmartFlash allows up to 90 percent of the air to be recirculated during flash mode.

### BOOTH CONSTRUCTION

Manufactured at our U.S. facility, Ultra XD Booths are constructed with white pre-coated sheet steel that is coated with a baked-on polyester topcoat for a rust-resistant cabin. Vertical wall panels and dual-skin construction create a smooth fit and finish.

### MORE BOOTH FEATURES

- Single-row pit (downdraft only)
- Three-wing, dual-skin product door
- Personnel door
- Choice of GFS' GUL2000, BT1200 or SpaceSaver® heat system (dependent upon airflow)
- Floor leveling system

### BOOTH OPTIONS

- Drive-thru configuration
- Four-wing, dual-skin product door
- Two- or three-row pit upgrade (downdraft only)
- LOGIC 3 or LOGIC 4 controls
- Six-tube, T8 LED light fixtures
- Raised basement (downdraft only; adds 13 inches to the overall height of the booth)
- Additional sidewall light fixtures
- Sidewall observation windows
- AdvanceCure System

Airflow	Inside Dimensions			Outside Dimensions*			No. of Light Fixtures		Product Door Opening	Air Heater	Single-Row Pit Length
	Width	Height	Length	Width	Height	Length	Ceiling	Sidewall			
Downdraft	14'	9'	24'	14' 5"	11'	24' 5"	8	4	9' 8" W x 8' 8" H	BTRC or GUL	21'
	14'	9'	24'	15' 4"	14' 7"	24' 5"	6	4	9' 8" W x 8' 8" H	Space-Saver	21'
	14'	9'	27'	14' 5"	11'	27' 5"	8	6	9' 8" W x 8' 8" H	BTRC or GUL	24'
	14'	9'	27'	15' 4"	14' 7"	27' 5"	8	6	9' 8" W x 8' 8" H	Space-Saver	24'
	14'	9'	30'	14' 5"	11'	30' 5"	10	6	9' 8" W x 8' 8" H	BTRC or GUL	27'
	14'	9'	30'	15' 4"	14' 7"	30' 5"	8	6	9' 8" W x 8' 8" H	Space-Saver	27'
Semi-Downdraft	14'	9'	24'	14' 5"	11'	24' 5"	6	4	9' 8" W x 8' 8" H	BTFD	No Pit
	14'	9'	27'	14' 5"	11'	27' 5"	8	6	9' 8" W x 8' 8" H	BTFD	No Pit
	14'	9'	27'	15' 4"	12' 7"	27' 5"	8	6	9' 8" W x 8' 8" H	Space-Saver	No Pit
	14'	9'	30'	14' 5"	11'	30' 5"	8	6	9' 8" W x 8' 8" H	BTFD	No Pit
	14'	9'	30'	15' 4"	12' 7"	30' 5"	8	6	9' 8" W x 8' 8" H	Space-Saver	No Pit

\*Floor-mounted air heater dimensions are not included in the outside dimensions. Additionally, if a floor leveling system is used, booth height may increase beyond the dimensions listed.



# EFFICIENT **ULTRA**<sup>®</sup> XS

The Ultra XS Paint Booth delivers the quality and performance you've come to expect from GFS' Ultra Booths in a durable, single-skin design. Available with downdraft or semi-downdraft airflow, several heater and control options, and multiple size configurations, Ultra XS provides flexibility and efficiency to suit the needs of any shop.

## BOOTH FEATURES

### AIRFLOW & CONTAMINATION CONTROL

Ultra XS Paint Booths come standard with GFS' patented Controlled Airflow Ceiling (in downdraft models) or the High-Performance Airflow Ceiling (in semi-downdraft models). Both ceilings allow for even distribution of air throughout the booth, providing excellent air filtration and precise contamination control.

### LIGHTING

Designed for optimal brightness, Ultra XS Booths feature four-tube sidewall light fixtures and either premium angled ceiling light fixtures (integrated into the Controlled Airflow Ceiling) or hip light fixtures (with the High-Performance Airflow Ceiling). All GFS light fixtures are ETL and ETL-C listed, and come complete with T8 ballasts and LED lamps.

### CONTROL PANEL

The Ultra XS comes standard with an easy-to-use Engage control panel. Enhancements such as a touch screen interface, energy-saving settings, pressure control and alarm tracking allow for better, more reliable booth performance. Upgrading to the LOGIC 3 or LOGIC 4 control panel provides additional functionality and user-programmable features such as SmartFlash and SmartCure profiles.

### ENERGY SAVINGS

Shops can save up to 60 percent in electricity and 75 percent in fuel costs with economy mode, which automatically ramps the booth down and runs on idle when the booth is not in use. Providing further energy savings, SmartFlash allows up to 90 percent of the air to be recirculated during flash mode.

### BOOTH CONSTRUCTION

Manufactured at our U.S. facility, Ultra XS Booths are constructed with single-skin, white pre-coated sheet steel that is coated with a baked-on polyester topcoat for a rust-resistant cabin. Vertical wall panels and exterior flanges create a smooth interior fit and finish.

### MORE BOOTH FEATURES

- Single-row pit (downdraft only)
- Three-wing, dual-skin product door
- Personnel door
- Choice of GFS' GUL2000, BT1200 or SpaceSaver heat system (dependent upon airflow)
- Floor leveling system

### BOOTH OPTIONS

- Drive-thru configuration
- Four-wing, dual-skin product door
- Two- or three-row pit upgrade (downdraft only)
- LOGIC 3 or LOGIC 4 controls
- Six-tube, T8 LED light fixtures
- Raised basement (downdraft only; adds 13 inches to the overall height of the booth)
- Additional sidewall light fixtures
- Sidewall observation windows
- AdvanceCure System



Airflow	Inside Dimensions			Outside Dimensions*			No. of Light Fixtures		Product Door Opening	Air Heater	Single-Row Pit Length
	Width	Height	Length	Width	Height	Length	Ceiling	Sidewall			
Downdraft	14'	9'	24'	14' 5"	11'	24' 5"	8	4	9' 8" W x 8' 8" H	BTRC or GUL	21'
	14'	9'	24'	15' 4"	14' 7"	24' 5"	6	4	9' 8" W x 8' 8" H	Space-Saver	21'
	14'	9'	27'	14' 5"	11'	27' 5"	8	6	9' 8" W x 8' 8" H	BTRC or GUL	24'
	14'	9'	27'	15' 4"	14' 7"	27' 5"	8	6	9' 8" W x 8' 8" H	Space-Saver	24'
	14'	9'	30'	14' 5"	11'	30' 5"	10	6	9' 8" W x 8' 8" H	BTRC or GUL	27'
	14'	9'	30'	15' 4"	14' 7"	30' 5"	8	6	9' 8" W x 8' 8" H	Space-Saver	27'
Semi-Downdraft	14'	9'	24'	14' 5"	11'	24' 5"	6	4	9' 8" W x 8' 8" H	BTFD	No Pit
	14'	9'	27'	14' 5"	11'	27' 5"	8	6	9' 8" W x 8' 8" H	BTFD	No Pit
	14'	9'	27'	15' 4"	12' 7"	27' 5"	8	6	9' 8" W x 8' 8" H	Space-Saver	No Pit
	14'	9'	30'	14' 5"	11'	30' 5"	8	6	9' 8" W x 8' 8" H	BTFD	No Pit
	14'	9'	30'	15' 4"	12' 7"	30' 5"	8	6	9' 8" W x 8' 8" H	Space-Saver	No Pit

\*Floor-mounted air heater dimensions are not included in the outside dimensions. Additionally, if a floor leveling system is used, booth height may increase beyond the dimensions listed.



# OVERSIZED ULTRA® XL

With a 12-foot-high ceiling designed for painting Sprinter vans, commercial vehicles and full-size pickup trucks, Ultra XL brings the performance you expect from the Ultra Paint Booth line to an extended range of vehicle sizes and heights. With premium brightness, contamination control, energy efficiency, and single- or dual-skin construction, Ultra XL is the perfect solution for oversized paint jobs.

## BOOTH FEATURES

### AIRFLOW & CONTAMINATION CONTROL

With a unique 14-foot-wide wide ceiling plenum, GFS' patented Controlled Airflow Ceiling increases the booth's spray zone. The main airflow zone in the Controlled Airflow Ceiling creates a protective envelope of air around the vehicle, while secondary airflow zones protect booth walls from overspray and keep contaminants out of the paint job.

### LIGHTING

Ultra XL Booths feature four-tube sidewall light fixtures and premium angled ceiling light fixtures, integrated into the Controlled Airflow Ceiling and located directly above the vehicle for optimal illumination. Light fixtures are ETL and ETL-C listed, and come complete with T8 ballasts and LED lamps.

### CONTROL PANEL

The Ultra XL comes standard with an easy-to-use Engage control panel. Enhancements such as a touch screen interface, energy-saving settings, pressure control and alarm tracking allow for better, more reliable booth performance. Upgrading to the LOGIC 3 or LOGIC 4 control panel provides additional functionality and user-programmable features such as SmartFlash and SmartCure profiles.

### ENERGY SAVINGS

Shops can save up to 60 percent in electricity and 75 percent in fuel costs with economy mode, which automatically ramps the booth down and runs on idle when the booth is not in use. Providing further energy savings, SmartFlash allows up to 90 percent of the air to be recirculated.

### BOOTH CONSTRUCTION

Manufactured at our U.S. facility, Ultra XL Booths are constructed with white pre-coated sheet steel that is coated with a baked-on polyester topcoat for a rust-resistant cabin.

### MORE BOOTH FEATURES

- Single-row pit
- Choice of single- or dual-skin construction
- Four-wing, dual-skin product door
- Personnel door
- Choice of GFS' GUL2000 or BT1200 heat system
- Floor leveling system

### BOOTH OPTIONS

- Drive-thru configuration
- Two- or three-row pit upgrade
- LOGIC 3 or LOGIC 4 controls
- Six-tube, T8 LED light fixtures
- Raised basement (adds 13 inches to the overall height of the booth)
- Additional sidewall light fixtures
- AdvanceCure System

Airflow	Inside Dimensions			Outside Dimensions*			No. of Light Fixtures		Product Door Opening	Air Heater	Single-Row Pit Length
	Width	Height	Length	Width	Height	Length	Ceiling	Sidewall			
Downdraft	14'	12'	27'	14' 5"	14'	27' 5"	8	6	10' 8" W x 11' 10" H	BTRC or GUL	24'
	14'	12'	30'	14' 5"	14'	30' 5"	10	6	10' 8" W x 11' 10" H	BTRC or GUL	27'

\*Floor-mounted air heater dimensions are not included in the outside dimensions. Additionally, if a floor leveling system is used, booth height may increase beyond the dimensions listed.



# REVO INTEGRATED ULTRA<sup>®</sup> XR

The Ultra XR Paint Booth from GFS is a premium downdraft spray booth that is integrated seamlessly with the REVO Speed – creating a top-of-the-line spraying and curing environment. By combining unparalleled contamination control and premium lighting with REVO Systems' innovative accelerated curing technology, GFS' Ultra XR Paint Booth provides the performance and versatility your paint shop needs to become more efficient, produce better quality paint jobs and reduce energy consumption.

## BOOTH FEATURES

### AIRFLOW & CONTAMINATION CONTROL

With a unique 14-foot-wide wide ceiling plenum, GFS' patented Controlled Airflow Ceiling increases the booth's spray zone. The main airflow zone in the Controlled Airflow Ceiling creates a protective envelope of air around the vehicle, while secondary airflow zones protect booth walls from overspray and keep contaminants out of the paint job.

### LIGHTING

Ultra XR Booths feature six-tube sidewall light fixtures and premium angled ceiling light fixtures, integrated into the Controlled Airflow Ceiling and located directly above the vehicle for optimal illumination. Light fixtures are ETL and ETL-C listed, and come complete with T8 ballasts and LED lamps.

### CONTROL PANEL

With a touch screen interface, energy-saving settings, spray temperature and booth mode monitoring, booth balancing and self diagnostics, the LOGIC 4 control panel provides complete control over the Ultra XR Paint Booth.

### ENERGY SAVINGS

Shops can save up to 60 percent in electricity and 75 percent in fuel costs with economy mode, which automatically ramps the booth down and runs on idle when the booth is not in use. Providing further energy savings, SmartFlash allows up to 90 percent of the air to be recirculated during flash mode. Additionally, shops can reduce energy costs by using the integrated REVO Speed, which consumes a fraction of the energy.

### BOOTH CONSTRUCTION

Manufactured at our U.S. facility, Ultra XR Booths are constructed with white pre-coated sheet steel that is coated with a baked-on polyester topcoat for a rust-resistant cabin. Vertical wall panels and dual-skin construction create a smooth fit and finish. Unique to the Ultra XR Paint Booth, a 10-foot interior height accommodates the REVO Speed and a wider array of vehicles.

### REVO SYSTEM INTEGRATION

An overhead rail system is integrated into the Ultra XR Paint Booth to allow the REVO Speed to move independently alongside the vehicle, curing coatings as it moves. To make the solution fully NFPA 33 compliant, pressurized power rails prevent overspray from entering the rails and a pressurized parking garage stores the REVO System to protect the unit from paint buildup and contaminants when not in use.

### MORE BOOTH FEATURES

- Two-row pit
- Four-wing, dual-skin product door
- One personnel door
- Upgraded GUL2000 air heater
- Floor leveling system

### BOOTH OPTIONS

- Drive-thru configuration
- Side-load configuration
- Three-row pit upgrade
- Raised basement (adds 13 inches to overall height of the booth)
- Additional sidewall light fixtures
- Sidewall observation windows
- AdvanceCure System



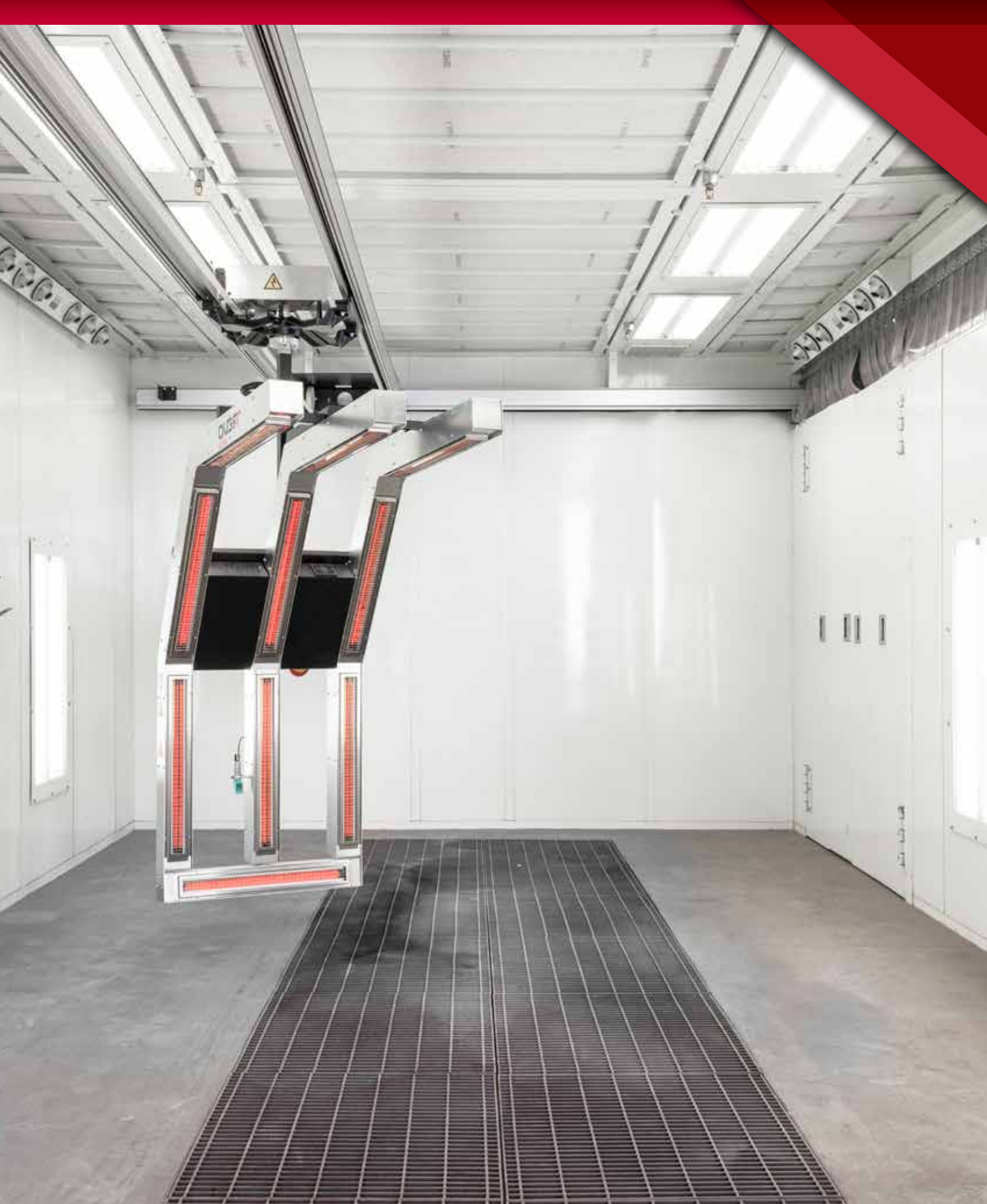

# PERFORMER<sup>®</sup> PAINT BOOTHS

Our most affordable automotive paint booth line, Performer Paint Booths from GFS allow body shops and collision centers of all sizes to achieve quality paint finishes in a safe, ecologically friendly environment. Performer Paint Booths feature bright, color-corrected lighting, quality construction, effective overspray capture and contamination control, and intuitive controls for an efficient, reliable painting environment.

Performer Booth models and standard options are fully ETL and ETL-C listed, ensuring that the entire booth complies with applicable safety codes and meets performance requirements. ETL listing facilitates successful inspections and demonstrates that Performer Booths have completed independent, third-party review.

## AIRFLOW

### DOWNDRAFT

Generally accepted as the best airflow style, downdraft booths do an excellent job of controlling overspray and contamination. Air enters the booth through a filtered ceiling plenum. From there, air flows vertically over the vehicle or part and into the filtered exhaust pit in the floor.

### SEMI-DOWNDRAFT

The semi-downdraft booth is a hybrid, combining features of both crossdraft and downdraft airflow styles. Air is introduced into the semi-downdraft booth through a filtered ceiling plenum in the first 25-30 percent of the booth. It is then pulled through the working chamber, over the vehicle or part and into the filtered exhaust chamber at the booth rear.

### CROSSDRAFT

The most cost-effective airflow style, crossdraft booths offer reliable performance at an affordable price point. Air enters through filtered product doors or plenum at the front of the booth, and flows horizontally over the vehicle or part and into the filtered exhaust chamber at the rear of the booth.

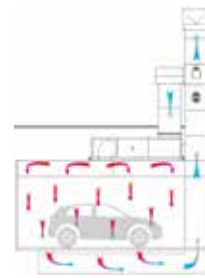

SpaceSaver Air Heater

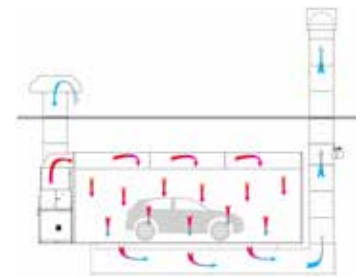

GUL2000/BT1200 Air Heater



SpaceSaver Air Heater



BT1200 Air Heater

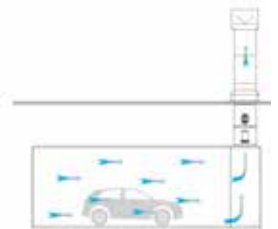

**Note:** Conceptual airflow representation, actual air heater layout may vary.

# PERFORMER<sup>®</sup> MATRIX

S - STANDARD

O - OPTION

N/A - NOT AVAILABLE

FEATURES		PERFORMER XP1	PERFORMER XD	PERFORMER ES
Airflow & Ceiling Type	Downdraft (High-Performance Airflow Ceiling)	S	S	N/A
	Semi-Downdraft (High-Performance Airflow Ceiling)	N/A	S	S
	Crossdraft	N/A	N/A	S
Exhaust System	Pit (downdraft models only)	S	S	N/A
	Raised Basement (downdraft models only)	O	O	N/A
	Filtered Exhaust Yoke (semi-downdraft & crossdraft models only)	N/A	S	S
	Filtered Exhaust Chamber (semi-downdraft & crossdraft models only)	N/A	N/A	S
Controls	LOGIC 4 (with SmartFlash, SmartCure and Economy Mode)	O	O	N/A
	LOGIC 3 (with SmartFlash, SmartCure and Economy Mode)	S	O	N/A
	Engage (with Economy Mode)	N/A	S	S
	Electromechanical Control Panel	N/A	N/A	S
Cure	Integrated AdvanceCure Blade	S	O	N/A
	Ready to integrate with AdvanceCure (Blades/Nozzles not included)	N/A	S	N/A
Air Heater	GUL2000 (downdraft models only)	S	N/A	N/A
	BT1200	N/A	S	S
	SpaceSaver	N/A	S	N/A
Lighting	Four-Tube, T8 LED Light Fixtures	N/A	S	S
	Six-Tube, T8 LED Light Fixtures	S	O	O
	Additional Sidewall Light Fixtures	O	O	N/A
Construction	Dual-Skin Insulated Panels	S	S	N/A
	Single-Skin Panels	N/A	N/A	S
	White Pre-Coated Panels	N/A	N/A	O
	Galvanized Panels	N/A	N/A	S
Doors	Personnel Door	S	S	S
	Three-Wing Product Door	S	S	N/A
	Two-Wing Product Door	N/A	N/A	S
	Drive-Thru Configuration	O	O	O

# QUALITY PERFORMER® XP1

The Performer XP1 is the fully loaded version of GFS' affordable paint booth line. With added features such as an integrated AdvanceCure System, two-row pit, best-in-class heater and LOGIC 3 control panel, the Performer XP1 takes the standard paint booth to a new level.

Airflow	Inside Dimensions			Outside Dimensions*			No. of Light Fixtures		Product Door Opening	Air Heater	Dual-Row Pit Length
	Width	Height	Length	Width	Height	Length	Ceiling	Sidewall			
Downdraft	14'	9'	27'	14' 5"	11'	27' 5"	8	4	9' 8" W x 8' 8" H	GUL	24'

\*Floor-mounted air heater dimensions are not included in the outside dimensions. Additionally, if a floor leveling system is used, booth height may increase beyond the dimensions listed.

## BOOTH FEATURES

### AIRFLOW

- High-Performance Airflow Ceiling
- Fully integrated AdvanceCure Blade Accelerated Airflow System
- 90/10 air recirculation during cure cycle

### CONSTRUCTION

- White pre-coated galvanized steel
- Dual-skin insulated panels
- Industry standard 10-foot-wide, 2-foot-high plenum
- Floor leveling system

### LIGHTING

- Six-tube, T8 LED light fixtures

### DOORS

- Three-wing entry door with three observation windows
- Personnel door with observation window

### HEATER

- Dual VFD
- 10 hp intake and exhaust motors
- 1.2 MBTU direct-fire burner

### CONTROLS

- LOGIC 3 control panel

## BOOTH OPTIONS

- Three-row pit
- Raised basement
- Drive-thru configuration
- Six-tube corner light fixtures
- Additional six-tube sidewall light fixtures
- Sidewall observation windows
- Control panel upgrade



# RELIABLE PERFORMER<sup>®</sup> XD

One of GFS' most popular automotive refinish booths, the Performer XD spray booth surpasses all others in its class. With excellent lighting, intuitive controls, effective contamination control and multiple booth options, the Performer XD is an affordable, versatile paint booth with many of the key features that you expect to see in a top-of-the-line booth.

Airflow	Inside Dimensions			Outside Dimensions*			No. of Light Fixtures		Product Door Opening	Air Heater	Single-Row Pit Length
	Width	Height	Length	Width	Height	Length	Ceiling	Sidewall			
Downdraft	14'	9'	27'	14' 5"	11'	27' 5"	8	4	9' 8" W x 8' 8" H	BTRC	24'
	14'	9'	30'	14' 5"	14' 6"	30' 8"	8	4	9' 8" W x 8' 8" H	SpaceSaver	27'
Semi-Downdraft	14'	9'	27'	14' 5"	11'	27' 5"	8	4	9' 8" W x 8' 8" H	BTFD	No Pit
	14'	9'	30'	14' 5"	14' 6"	30' 8"	8	4	9' 8" W x 8' 8" H	SpaceSaver	No Pit

\*Floor-mounted air heater dimensions are not included in the outside dimensions. Additionally, if a floor leveling system is used, booth height may increase beyond the dimensions listed.

## BOOTH FEATURES

### AIRFLOW

- High-Performance Airflow Ceiling

### CONSTRUCTION

- White pre-coated galvanized steel
- Dual-skin insulated panels
- Industry standard 10-foot-wide, 2-foot-high plenum
- Exhaust chamber (semi-downdraft configuration)

### LIGHTING

- Four-tube, T8 LED light fixtures

### DOORS

- Three-wing entry door with one observation window
- Personnel door with observation window

### CONTROLS

- Engage control panel

## BOOTH OPTIONS

- Two or three-row pit (downdraft only)
- Raised basement (downdraft only)
- AdvanceCure System
- Drive-thru configuration (four-wing door not available on semi-downdraft models)
- Six-tube, T8 LED light fixtures
- Four- or six-tube, T8 LED corner or sidewall light fixtures
- Control panel upgrade
- Exhaust yoke (adds 3 feet 3 inches to the internal working space) semi-downdraft only
- Additional product door windows



# AFFORDABLE PERFORMER<sup>®</sup> ES

The Performer ES spray booth was designed and built for the value-minded shop owner. Quality construction, durable hardware and reliable performance make the Performer ES Paint Booth an excellent choice for shops in need of an affordable all-in-one paint environment.

Airflow	Inside Dimensions			Outside Dimensions*			No. of Light Fixtures		Product Door Opening
	Width	Height	Length	Width	Height	Length	Ceiling	Sidewall	
Semi-Downdraft (Pressurized or Non-Pressurized)	14'	9'	24'	15'	11' 2"	24' 6"	6	4	9' 11" W x 8' 9" H
	14'	9'	27'	15'	11' 2"	27' 6"	6	4	9' 11" W x 8' 9" H
	14'	9'	30'	15'	11' 2"	30' 6"	8	4	9' 11" W x 8' 9" H
Crossdraft (Non-Pressurized)	14'	9'	24'	15'	9' 4"	24' 6"	6	4	9' 11" W x 8' 9" H
	14'	9'	27'	15'	9' 4"	27' 6"	6	4	9' 11" W x 8' 9" H
	14'	9'	30'	15'	9' 4"	30' 6"	8	4	9' 11" W x 8' 9" H

\*Floor-mounted air heater dimensions are not included in the outside dimensions.

## BOOTH FEATURES

### AIRFLOW

- Filtered ceiling plenum
- Filtered product doors on crossdraft models

### CONSTRUCTION

- Single-skin, galvanized steel panels
- Industry standard 10-foot-wide, 2-foot-high plenum on semi-downdraft models

### LIGHTING

- Four-tube, T8 LED light fixtures

### DOORS

- Swing door entry
- Personnel door with observation window

### EXHAUST

- 30-inch tube axial exhaust fan with 3 hp motor
- Solid back exhaust wall

### CONTROLS

- Electromechanical controls including UL listed panel, motor starter and air solenoid valve

## BOOTH OPTIONS

- White pre-coated panels
- Drive-thru configuration replaces exhaust wall with an exhaust yoke (four-wing door not available on semi-downdraft models)
- Ductwork kit, including straight duct for a 15-foot ceiling; roof flange not included (semi-downdraft only)
- Pressurizing kit for intake fan, includes 15-foot twin forward curved fan with 3 hp motor and control panel. This option pulls shop air (semi-downdraft only)
- Pressurizing with BTFD1200 forced dry heater, includes Engage control panel and 34-foot ductwork kit for 15-foot ceiling (semi-downdraft only)



# ULTRA<sup>®</sup> CTOF BOOTHS

Versatile, end-to-end finishing environments, Ultra Closed-Top Open-Front (CTOF) Booths from Global Finishing Solutions allow for vehicles to be filled, primed, sealed, painted and cured in one location.

Pre-engineered Ultra CTOF Booth models and standard options are fully ETL and ETL-C listed, ensuring that the entire booth complies with applicable safety codes and meets performance requirements. ETL listing facilitates successful inspections and demonstrates that Ultra CTOF Booths have completed independent, third-party review.



## HIGH-PERFORMANCE AIRFLOW

### DOWNDRAFT

Generally accepted as the best airflow style, downdraft booths do an excellent job of controlling overspray and contamination. Air enters Ultra CTOF Booths through a filtered ceiling plenum. From there, air flows vertically over the vehicle or part and into the filtered exhaust pit in the floor.

### SEMI-DOWNDRAFT

The semi-downdraft booth is a hybrid, combining features of both crossdraft and downdraft airflow styles. Air is introduced into the semi-downdraft Ultra CTOF Booth through a filtered ceiling plenum in the first 25-30 percent of the booth. It is then pulled through the working chamber, over the vehicle or part and into the filtered exhaust chamber at the booth rear.

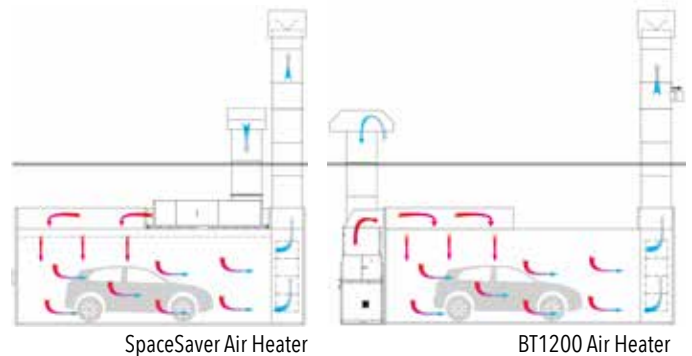
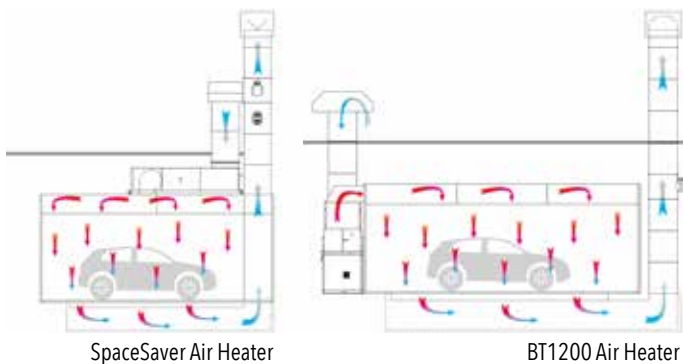

**Note:** Conceptual airflow representation, actual air heater layout may vary.

# ULTRA<sup>®</sup> CTOF MATRIX

S - STANDARD

O - OPTION

N/A - NOT AVAILABLE

FEATURES		Ultra XD CTOF		Ultra XS CTOF	
		Single-Bay	Dual-Bay	Single-Bay	Dual-Bay
Airflow & Ceiling Type	Downdraft	S	S	S	S
	Semi-Downdraft	S	S	S	S
	High-Performance Airflow Ceiling	S	S	S	S
Exhaust System	Pit (downdraft models only)	S	S	S	S
	Non-Filtered Exhaust Yoke (downdraft models with SpaceSaver heater)	S	S	S	S
	Filtered Exhaust Yoke (semi-downdraft models only)	S	S	S	S
Controls	LOGIC 4 (with SmartFlash, SmartCure and Economy Mode)	O	O	O	O
	LOGIC 3 (with SmartFlash, SmartCure and Economy Mode)	O	O	O	O
	Engage (with Economy Mode)	S	S	S	S
Cure	Integrated AdvanceCure System	O	O	O	O
Air Heater	BT1200	N/A	S	N/A	S
	SpaceSaver	S	S	S	S
Lighting	Four-Tube, T8 LED Light Fixtures	S	S	S	S
	Six-Tube, T8 LED Light Fixtures	O	O	O	O
	Sidewall Light Fixtures	O	O	O	O
Construction	Dual-Skin Insulated Panels	S	S	N/A	N/A
	Single-Skin Panels	N/A	N/A	S	S
	Floor Leveling System	S	S	S	S
Doors	Personnel Door	S	S	S	S
	Front Curtain(s)	S	S	S	S
	Divider Curtain	N/A	S	N/A	S
	Three-wing Product Door	N/A	O	N/A	O
	Drive-Thru Configuration	O	O	O	O



# ULTRA<sup>®</sup> XD CTOF

Ultra XD CTOFs are the ideal complement to our top-of-the-line paint booths. With dual-skin walls and superior construction, airflow and lighting, the Ultra XD CTOF is a premium environment for prepping and painting.

Airflow	Bays	Inside Dimensions			Outside Dimensions*			No. of Hip Light Fixtures	Air Heater	Single Row Pit Length (Downdraft)
		Width	Height	Length	Width	Height	Length			
Downdraft OR Semi-Downdraft	Single	14'	9'	24'	14' 8"	11'	24' 8"	8	SpaceSaver	21'
		14'	9'	27'	14' 8"	11'	27' 8"	8	SpaceSaver	24'
	Dual	24'	9'	24'	24' 8"	11'	24' 8"	12	BTFD or SpaceSaver	21' (2)
		24'	9'	27'	24' 8"	11'	27' 8"	16	BTFD or SpaceSaver	24' (2)

\* Floor-mounted air heater dimensions are not included in the outside dimensions. Additionally, if a floor leveling system is used, booth height may increase beyond the dimensions listed.

## BOOTH FEATURES

### AIRFLOW

- High-Performance Airflow Ceiling

### CONSTRUCTION

- White pre-coated galvanized steel
- Dual-skin insulated panels
- Self-supporting structure design
- Solid back wall panels
- Floor leveling system

### LIGHTING

- Four-tube, T8 LED light fixtures

### DOORS

- Front curtain(s)
- Divider curtain for dual-bay models
- Personnel door with observation window

### CONTROLS

- Engage control panel

## BOOTH OPTIONS

- Two- or three-row pit (downdraft only)
- AdvanceCure System
- Drive-thru configuration (four-wing doors are not available on semi-downdraft models)
- Six-tube, T8 LED light fixtures
- Four- or six-tube corner or sidewall light fixtures
- Three- or four-wing doors (dual-bay only)
- Control panel upgrade



# ULTRA<sup>®</sup> XS CTOF

Ultra XS CTOF is an affordable, all-in-one area for prepping and painting vehicles. Single-skin walls provide cost savings without compromising quality. An expansive CTOF line, choose from downdraft or semi-downdraft airflow, and a wide variety of sizes.

Airflow	Bays	Inside Dimensions			Outside Dimensions*			No. of Hip Light Fixtures	Air Heater	Single Row Pit Length (Downdraft)
		Width	Height	Length	Width	Height	Length			
Downdraft OR Semi-Downdraft	Single	14'	9'	24'	14' 8"	11'	24' 8"	8	SpaceSaver	21'
		14'	9'	27'	14' 8"	11'	27' 8"	8	SpaceSaver	24'
	Dual	24'	9'	24'	24' 8"	11'	24' 8"	12	BTFD or SpaceSaver	21' (2)
		24'	9'	27'	24' 8"	11'	27' 8"	16	BTFD or SpaceSaver	24' (2)

\* Floor-mounted air heater dimensions are not included in the outside dimensions. Additionally, if a floor leveling system is used, booth height may increase beyond the dimensions listed.

## BOOTH FEATURES

### AIRFLOW

- High-Performance Airflow Ceiling

### CONSTRUCTION

- Single-skin, pre-coated white panels
- Self-supporting structure design
- Solid back wall panels
- Floor leveling system

### LIGHTING

- Four-tube, T8 LED light fixtures

### DOORS

- Front curtain(s)
- Divider curtain for dual-bay models
- Personnel door with observation window

### CONTROLS

- Engage control panel

### BOOTH OPTIONS

- Two- or three-row pit (downdraft only)
- AdvanceCure System
- Drive-thru configuration (four-wing doors are not available on semi-downdraft models)
- Six-tube, T8 LED light fixtures
- Four- or six-tube corner or sidewall light fixtures
- Three- or four-wing doors (dual-bay only)
- Control panel upgrade



# ULTRA<sup>®</sup> XR CTOF

A versatile, end-to-end finishing environment, the Ultra XR CTOF allows for vehicles to be filled, primed, sealed, painted and cured in one location. The Ultra XR CTOF is fully integrated with REVO Accelerated Curing Systems, eliminating bottlenecks and adding speed and flexibility to your shop's processes. A built-in overhead rail system allows REVO Speed or Rapid to easily move alongside the vehicle or panels.

## BOOTH FEATURES

### AIRFLOW

- Dwindraft airflow with GFS' exclusive Controlled Airflow Ceiling

### CONSTRUCTION

- Dual-bay
- White pre-coated galvanized steel
- Dual-skin insulated panels
- Self-supporting structure design
- Solid back wall panels
- Floor leveling system

### LIGHTING

- Four-tube, T8 LED light fixtures

### DOORS

- Front curtains
- Divider curtain
- Personnel door with observation window

### CONTROLS

- LOGIC 4 control panel

### REVO SYSTEM INTEGRATION

- REVO Speed or Rapid OR2 System
- Built-in overhead rail system
- Pressurized parking garage

### BOOTH OPTIONS

- Two- or three-row pit
- AdvanceCure System
- Drive-thru configuration
- Sideload configuration
- Six-tube, T8 LED light fixtures
- Four- or six-tube corner or sidewall light fixtures
- Three- or four-wing doors



# EXCEL<sup>®</sup> WORKSTATIONS

Designed to meet the requirements of EPA's 6H Paint Rule (40CFR63 Subpart HHHHHH), GFS' Excel Workstation provides a controlled environment for sanding, priming and limited painting. When painting, the amount of material sprayed shall not exceed one gallon in an eight-hour period.

The Excel Workstation is available in multiple length, width and height options to suit any shop layout. Structure can be freestanding, with structural steel supports, or suspended from your shop ceiling.

## FEATURES

### AIRFLOW

- Semi-downdraft airflow
- Overhead filtered plenum (single or dual)
- 9-inch double width, double inlet, forward intake fan
- Tube axial exhaust fan

### CONSTRUCTION

- White pre-coated galvanized steel
- Column supported or suspended from shop ceiling
- Solid back or drive-thru configuration
- Heavy-duty, non-combustible curtain walls

### LIGHTING

- Four-tube, T8 LED light fixtures

### CONTROLS

- Basic control panel for lights and fan

### OPTIONS

- Six-tube, T8 LED light fixtures
- Exhaust ductwork



	Inside Dimensions			No. of Ceiling Light Fixtures	Intake Fan(s)
	Width	Height	Length		
Single	12'	9'	24'	5	1
	12'	9'	27'	6	1
	12'	9'	30'	7	1
	12'	12'	24'	5	1
	12'	12'	27'	6	1
	12'	12'	30'	7	1
Dual	24'	9'	24'	10	2
	24'	12'	24'	10	2

# EXCEL<sup>®</sup> WORKSTATIONS

## WALL CURTAINS

Separate your prep environment from the rest of the shop and maximize usable space. This retractable barrier confines dirt, dust and contaminants, while controlling cold loss. All materials meet NFPA 701 for fire retardancy.

## EXHAUST BOX

Designed for prepping and sanding operations, the Exhaust Box helps keep your shop clean by pulling dirt and dust into the exhaust chamber. Exhaust Boxes are not designed for spray painting or priming. If spraying does occur in the Exhaust Box, it would be classified as an unenclosed spraying area.

### FEATURES

- White pre-coated galvanized steel
- Exhaust fan, motor and duct
- Control package
- Duct package for 15-foot roof height

	Inside Dimensions			Exhaust Fan	Motor
	Width	Height	Length		
Single	10'	11'	1' 8"	18"	2 hp
	20'	11'	1' 8"	24"	2 hp

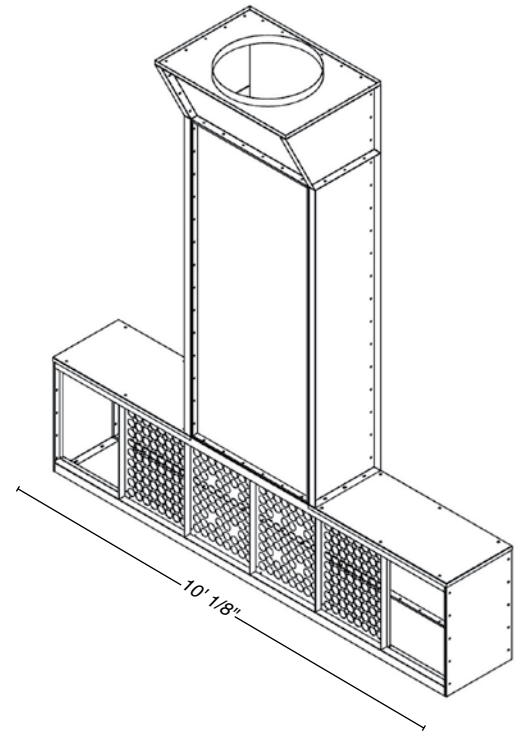

# ALUMINUM REPAIR

Aluminum Repair Stations from GFS are flexible, effective solutions for the isolation of aluminum repair processes. A dedicated environment for aluminum repairs is essential to protect your employees and prevent contamination from compromising the repair. Three models of Aluminum Repair Stations are available to meet the cost and space restrictions of all types of shops.

## DIMENSIONS & FEATURES

Inside Dimensions			No. of Ceiling Light Fixtures
Width	Height	Length	
14' or 16'	9' or 12'	27'	6
14' or 16'	9' or 12'	30'	7
14' or 16'	9' or 12'	33'	8

\*Lights are only available on Aluminum Repair Station Plus and Aluminum Repair Station.

## ALUMINUM REPAIR STATION PLUS®

Featuring heavy-duty curtain walls, four-tube light fixtures and semi-downdraft airflow with an overhead filtered plenum, GFS' Aluminum Repair Station Plus is a high-performance environment for aluminum repair. It can also be used for spot painting and other repairs for maximum productivity and flexibility.



Aluminum Repair Station Plus exhaust system is intended for priming and prep processes only, and is not suitable for extraction or containment of explosive aluminum dust. Aluminum dust extraction system must be installed and used for aluminum repair work.

## FEATURES

### AIRFLOW

- Exhaust filter isolation shield
- 9-inch double width, double inlet, forward intake fan
- Tube axial exhaust fan

### CONSTRUCTION

- Semi-downdraft airflow with overhead filtered plenum (single)
- White pre-coated galvanized steel construction
- Heavy-duty, non-combustible, clear-view curtain walls
- Column supported or suspended from shop ceiling
- Drive-thru configuration with back curtain wall

### LIGHTING

- Four-tube, T8 LED light fixtures

### CONTROLS

- Basic control panel for lights and fan

### OPTIONS

- Exhaust ductwork
- Weld-view curtain

# ALUMINUM REPAIR

## ALUMINUM REPAIR STATION

In addition to heavy-duty, non-combustible curtain walls, the Aluminum Repair Station features a ceiling with integrated LED light fixtures for proper illumination and added protection against contamination.

- White pre-coated galvanized steel construction
- Three- or four-sided, heavy-duty, non-combustible, clear-view curtain walls
- Column supported or suspended from shop ceiling
- Four-tube, T8 LED light fixtures
- On/off switch for light fixtures



## ALUMINUM REPAIR ISOLATION STATION®

GFS' most cost-effective environment for aluminum repair, the Aluminum Repair Isolation Station features heavy-duty, non-combustible curtain walls to prevent against contamination during the aluminum repair process.

- Three- or four-sided, heavy-duty, non-combustible, clear-view curtain walls
- Suspended from shop ceiling (cabling not included)



# ULTRA<sup>®</sup> XD PAINT MIX ROOMS

Paint mixing rooms are used to control contamination and remove harmful fumes during the paint mixing process. GFS' paint mix rooms are available in multiple configurations, and can be connected to paint booths for direct entry. All of our mix rooms feature a 4-inch, integrated spill containment for confining potential spills, eliminating the need for a curb.

Premium Ultra XD Paint Mix Rooms feature dual-skin, insulated panels and are designed to integrate seamlessly with Ultra XD and XP1 Paint Booths.

## FEATURES

### CONSTRUCTION

- 4-inch spill containment
- White pre-coated galvanized steel
- Dual-skin insulated panels
- Floor leveling system

### LIGHTING

- Four-tube, T8 LED light fixtures

### DOORS

- Personnel door with observation window

### EXHAUST

- Exhaust blower with 1/2 hp motor (120V, 1-phase)

### CONTROLS

- Light switch and fan disconnect

## OPTIONS

- Pressurizing blower with 1/2 hp motor (120V, 1-phase)
- Observation window panel
- Raised basement
- Additional access door
- Mix room heater
- Exhaust stack kit
- Rotating booth access table
- Vestibule
- Control panel

## MULTIPLE CONFIGURATIONS

### FOUR-WALL

- Freestanding mix rooms available in a variety of standard configurations

### THREE-WALL

- Mix room connects to your paint booth for direct entry

### TWO-WALL

- Intermediate mix room connects two booths



\*Purchased and installed with the booth, the Rotating Access Table installs in the wall between the paint booth and mix room, providing access to pre-mixed paint and supplies, without having to leave the booth.



# ULTRA<sup>®</sup> XD PAINT MIX ROOMS

Dual-Skin Paint Mix Room Model No.	Inside Dimensions			No. of Walls	No. of Ceiling Light Fixtures
	Length	Width	Height		
UMRW-060909-2	6'	9'	9'	2	1
UMRW-060909-3	6'	9'	9'	3	1
UMRW-060909-4	6'	9'	9'	4	1
UMRW-061209-2	6'	12'	9'	2	2
UMRW-061209-3	6'	12'	9'	3	2
UMRW-061209-4	6'	12'	9'	4	2
UMRW-061509-2	6'	15'	9'	2	3
UMRW-061509-3	6'	15'	9'	3	3
UMRW-061509-4	6'	15'	9'	4	3
UMRW-090609-2	9'	6'	9'	2	1
UMRW-090609-3	9'	6'	9'	3	1
UMRW-090609-4	9'	6'	9'	4	1
UMRW-090909-2	9'	9'	9'	2	2
UMRW-090909-3	9'	9'	9'	3	2
UMRW-090909-4	9'	9'	9'	4	2
UMRW-091209-2	9'	12'	9'	2	2
UMRW-091209-3	9'	12'	9'	3	2
UMRW-091209-4	9'	12'	9'	4	2
UMRW-091509-2	9'	15'	9'	2	3
UMRW-091509-3	9'	15'	9'	3	3
UMRW-091509-4	9'	15'	9'	4	3
UMRW-120609-2	12'	6'	9'	2	2
UMRW-120609-3	12'	6'	9'	3	2
UMRW-120609-4	12'	6'	9'	4	2
UMRW-120909-2	12'	9'	9'	2	2
UMRW-120909-3	12'	9'	9'	3	2
UMRW-120909-4	12'	9'	9'	4	2
UMRW-121209-2	12'	12'	9'	2	2
UMRW-121209-3	12'	12'	9'	3	2
UMRW-121209-4	12'	12'	9'	4	2
UMRW-150609-2	15'	6'	9'	2	3
UMRW-150609-3	15'	6'	9'	3	3
UMRW-150609-4	15'	6'	9'	4	3
UMRW-150909-2	15'	9'	9'	2	3
UMRW-150909-3	15'	9'	9'	3	3
UMRW-150909-4	15'	9'	9'	4	3

# ULTRA<sup>®</sup> XS PAINT MIX ROOMS

Ultra XS Mix Rooms feature single-skin design and are the perfect companion for GFS' Ultra XS and single-skin Performer Paint Booths.

Single-Skin Paint Mix Room Model No.	Inside Dimensions			No. of Walls	No. of Ceiling Light Fixtures
	Length	Width	Height		
<b>VMRW-090609-4</b>	9'	6'	9'	4	1
<b>VMRW-090909-4</b>	9'	9'	9'	4	2
<b>VMRW-120609-4</b>	12'	6'	9'	4	2
<b>VMRW-120909-4</b>	12'	9'	9'	4	2
<b>VMRW-150909-4</b>	15'	9'	9'	4	3

## FEATURES

### CONSTRUCTION

- 4-inch spill containment
- White pre-coated galvanized steel
- Single-skin panels
- Floor leveling system

### LIGHTING

- Four-tube, T8 LED light fixtures

### DOORS

- Personnel door with observation window

### EXHAUST

- Exhaust blower with 1/2 hp motor (120V, 1-phase)

### CONTROLS

- Light switch and fan disconnect

## OPTIONS

- Pressurizing blower with 1/2 hp motor (120V, 1-phase)
- Door cover (required to connect mix room to booth)
- Observation window
- Vestibule
- Additional access door
- Mix room heater
- Exhaust stack kit
- Control panel



# GUL2000 AIR HEATER

GFS' top-of-the-line heat system, GUL2000 heat units are standard on all Ultra XP1 and Performer XP1 booth packages, and can be added to other GFS automotive booth models. Features such as an exhaust VFD, LOGIC control panel and direct-drive motors make this heat system highly efficient.

Intake Motor	Exhaust Motor	Intake Fan	Exhaust Fan	Direct-Fire Aluminum Burner	VFD
10 hp direct-drive	10 hp direct-drive	Airfoil Centrifugal		1.2 MBTU (Natural gas or propane fuel)	10 hp exhaust

## FEATURES

- Pre- and post-filtration
- Automatic pressure control (Auto Balance)
- Dual high limit switches
- Dual VFD package
- Door safety interlock switch, 24V
- 90/10 air recirculation during cure cycle
- LOGIC 3 control panel
- 34-inch round intake and exhaust duct for 15-foot roof



## OPTIONS

- 15 hp motor upgrade
- 1.5 MBTU upgrade
- LOGIC 4 control panel
- Filter monitoring
- Low NOx burner
- Low pressure burner

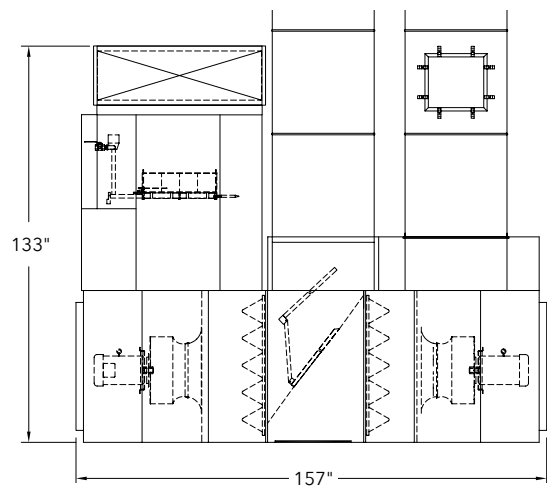

## UNIQUE GFS HEATER FEATURES

### REVERSE INCLINE, DIRECT-DRIVE, AIRFOIL CENTRIFUGAL FAN

(Intake and Exhaust)



This high-efficiency fan maintains consistent airflow, even when filters load up and cause increased resistance. Inferior fans cannot withstand the pressure.

The aluminum, non-sparking airfoil design delivers higher performance while consuming far less energy. The fan requires much less maintenance because there are no belts, pulleys and bearings to replace.

### DIRECT FIRE BURNER

With a high turndown ratio and faster cabin temperature rise, direct fire burners are more efficient than indirect heat exchangers. The direct fire burner is made of corrosion-resistant aluminum for reduced maintenance and longer life.

### NO-DAMPER BOOTH BALANCING

By using variable frequency drives (VFDs) and an innovative pressure transducer, GFS has eliminated the need for dampers to balance the booth. This allows for better performance and less maintenance.

# BT1200 AIR HEATER

Highly versatile, GFS' BT1200 heat unit can be placed on the side or rear of a paint booth, and is available in both recirculating and forced dry models.

Unit	Intake Motor	Exhaust Motor	Intake Fan	Exhaust Fan	Direct-Fire Aluminum Burner	VFD
Recirculating	10 hp direct-drive	7.5 hp belt-driven	Airfoil Centrifugal	34" tube axial	1.2 MBTU (Natural gas or propane fuel)	7.5 hp exhaust
Forced Dry (Semi-Downdraft)	10 hp direct-drive	7.5 hp belt-driven	Airfoil Centrifugal	34" tube axial	1.2 MBTU (Natural gas or propane fuel)	Dual VFD (10 hp intake & 7.5 hp exhaust)

## FEATURES

- Pre-filtration
- Side- or rear-mounted
- Automatic pressure control (Auto Balance)
- Dual high limit switches
- Dual VFD package
- Door safety interlock switch, 24V
- Engage control panel
- 34-inch round intake and exhaust duct for 15-foot roof



## OPTIONS

- 15 hp motor upgrade
- 1.5 MBTU upgrade
- LOGIC 3 or LOGIC 4 control panel
- Filter monitoring
- Semi-downdraft recirculation package (90/10)
- Low NOx burner
- Low pressure burner

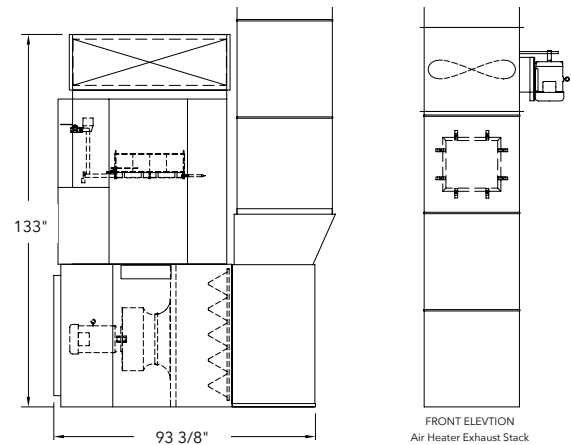

## UNIQUE GFS HEATER FEATURES

### REVERSE INCLINE, DIRECT-DRIVE, AIRFOIL CENTRIFUGAL FAN (Intake)



This high-efficiency fan maintains consistent airflow, even when filters load up and cause increased resistance. Inferior fans cannot withstand the pressure.

The aluminum, non-sparking airfoil design delivers higher performance while consuming far less energy. The fan requires much less maintenance because there are no belts, pulleys and bearings to replace.

### DIRECT FIRE BURNER

With a high turndown ratio and faster cabin temperature rise, direct fire burners are more efficient than indirect heat exchangers. The direct fire burner is made of corrosion-resistant aluminum for reduced maintenance and longer life.

### NO-DAMPER BOOTH BALANCING

By using variable frequency drives (VFDs) and an innovative pressure transducer, GFS has eliminated the need for dampers to balance the booth. This allows for better performance and less maintenance.

# SPACESAVER® AIR HEATER

GFS' exclusive roof-integrated SpaceSaver heat system does not add on to the paint booth's footprint and provides high performance in a low-profile package. By effectively compacting a high-efficiency heat system, GFS has opened up new possibilities for booth placement and shop layouts for space-conscious businesses.

Intake Motor	Exhaust Motor	Intake Fan	Exhaust Fan	Direct-Fire Aluminum Burner	VFD
Belt-Driven					
7.5 hp	5 hp	Matched high-efficiency turbo fan	34" tube axial	1.139 MBTU (Natural gas, propane fuel)	5 hp exhaust
10 hp	7.5 hp		34" tube axial	1.433 MBTU (Natural gas, propane fuel)	7.5 hp exhaust
15 hp	7.5 hp		34" tube axial	1.7 MBTU (Natural gas, propane fuel)	7.5 hp exhaust

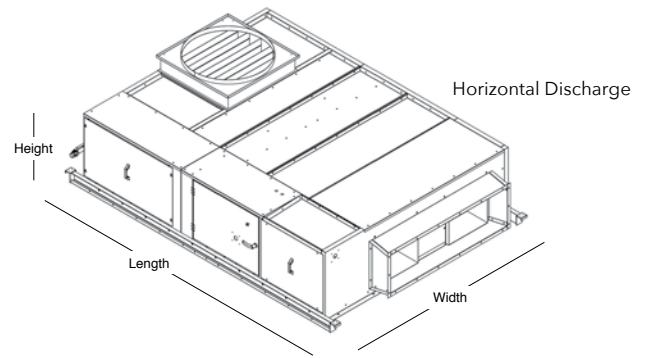
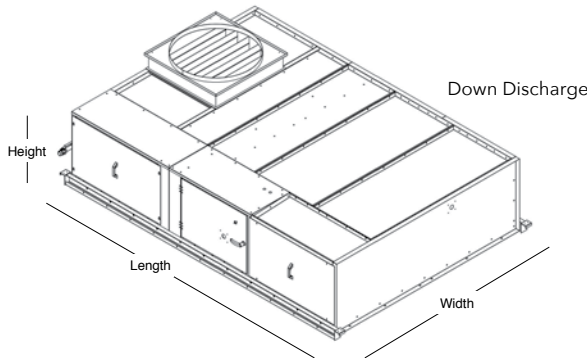

Low NOx			Forced Dry			Recirculation		
Width*	Height	Length	Width*	Height	Length	Width*	Height	Length
8' 2"	3' 8"	11' 4" Down Discharge, 11' 7" Horizontal Discharge	8' 2"	2' 9"	11' 4" Down Discharge, 11' 7" Horizontal Discharge	8' 2"	3' 6"	11' 4" Down Discharge, 11' 7" Horizontal Discharge

\*SpaceSaver air heater widths shown include the support cover angle and channel. Standalone, these air heaters are 7 ft. 10 in. wide.

## FEATURES

- Roof-mounted with low clearance
- 90/10 cabin recirculation during bake cycle
- Automatic pressure control (Auto Balance)
- Dual high limit switches
- Dual VFD package
- Door safety interlock switch, 24V
- Prefiltration
- Engage control panel
- 34-inch round intake and exhaust duct for 15-foot roof

## OPTIONS

- LOGIC 3 or LOGIC 4 control panel
- Forced dry
- Low NOx burner

## UNIQUE GFS HEATER FEATURES

### DIRECT FIRE BURNER

With a high turndown ratio and faster cabin temperature rise, direct fire burners are more efficient than indirect heat exchangers. The direct fire burner is made of corrosion-resistant aluminum for reduced maintenance and longer life.

# REVO ACCELERATED CURING SYSTEMS

## FASTER REPAIRS. BETTER RESULTS.

Improve your paint shop efficiency without having to overhaul your space with REVO Accelerated Curing Systems from Global Finishing Solutions. The revolutionary technology cures filler and coatings quickly from the inside out, offering the fastest curing time in the industry for both prep and paint processes.

Using short wave electric infrared technology, REVO Systems cure filler and coatings quickly from the inside out. The drying energy is concentrated on only the panels needing repair and penetrates multiple layers of coatings to the substrate beneath – for a consistent, complete cure.

Curing time for both prep and paint phases of repair can be reduced by hours, freeing up your technicians to complete additional repairs. The fast dry time and complete cure from electric IR technology delivers high-quality results that reduce the need for rework.

In addition to providing significant throughput gains and quality improvements, REVO Systems offer energy cost savings. Electric IR energy costs are a fraction of those needed to run a conventional system.

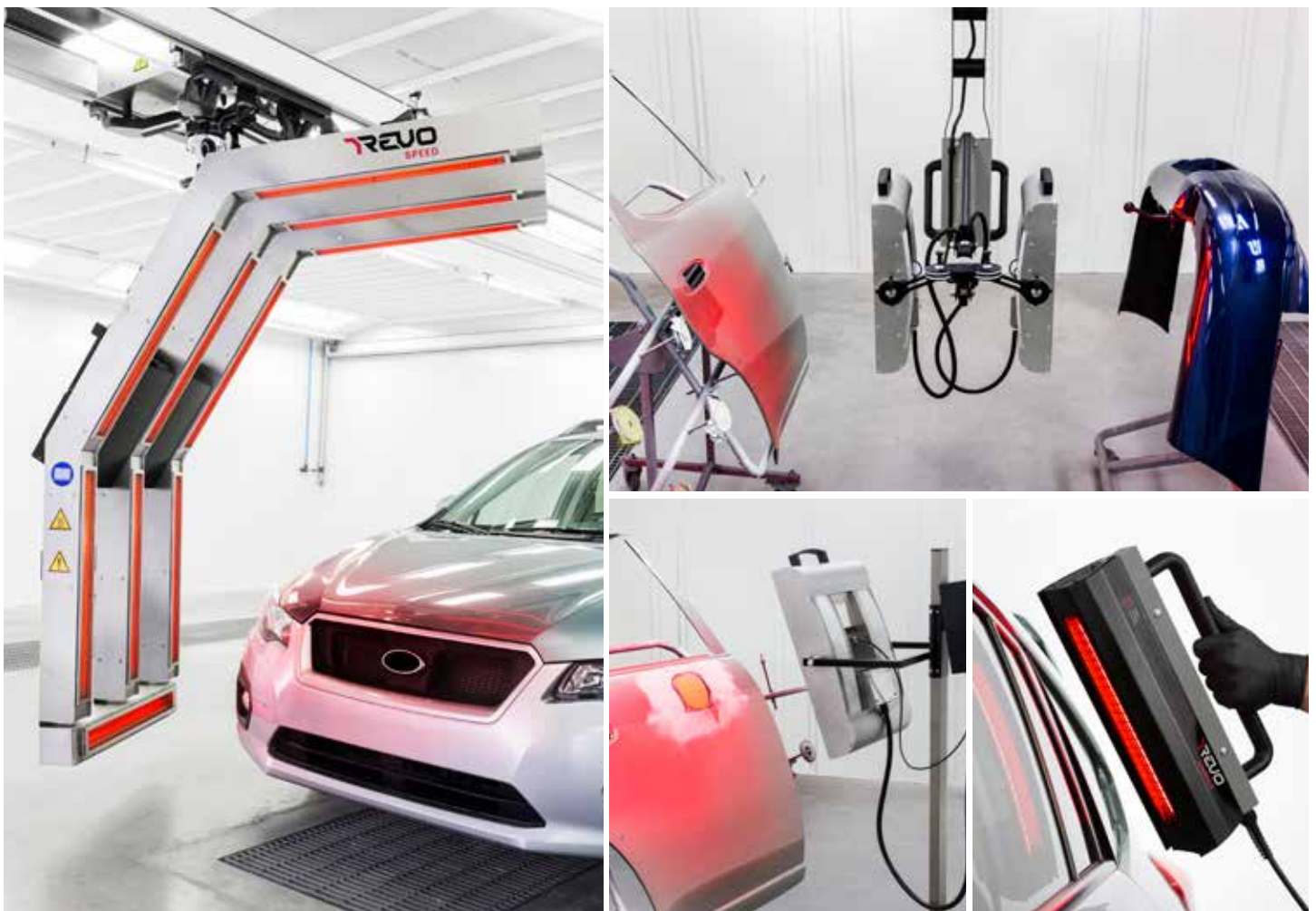

# REVO ACCELERATED CURING SYSTEMS

## REVO SPEED

THE ULTIMATE TOOL TO CUT PAINT TIME IN HALF.

The fast positioning of REVO Speed makes this premium model best suited for body shops that perform large volumes of average repairs on one to four panels. It can accommodate all sizes of passenger vehicles including cars, trucks, minivans and SUVs, as well as factory lifted trucks.

- Semi-automatic operation
- No need to scan vehicle or use plates or markers
- Easily switch lamps on/off
- Easy-to-use controls and sensors
- Repair panels on or off the vehicle
- Fans cool unit within seconds



## REVO RAPID

THE ULTIMATE TOOL FOR PAINT & PREP.

REVO Rapid is designed for full panel repairs or body shops with space restrictions. The REVO Rapid is available on an overhead rail system (OR2) or on a mobile cart with wheels (MC2). Both models feature dual sensors to safely and efficiently cure coatings on two different substrates simultaneously.

- Virtually unlimited orientations
- Temperature sensors on each cassette automatically adjust the intensity of the lamps to maintain a consistent temperature regardless of the substrate underneath, ensuring that you never overcure or undercure a coating
- Overhead rail units move easily around paint booths or prep areas with no cords to trip over
- Mobile units can be moved quickly around a shop wherever needed
- Easy-to-use controls
- 12 kw of power



## REVO SPOT

THE ULTIMATE TOOL FOR PRIMER & FILLER.

The single cassette REVO Spot is a great solution for quickly curing small surfaces. The REVO Spot can be effortlessly moved into any paint booth, prep station or virtually any other area in a shop.

- Ideal for small areas and spot repairs
- The temperature sensor automatically adjusts the intensity of the lamps to maintain a consistent temperature regardless of the substrate underneath, ensuring that you never overcure or undercure a coating
- Easy-to-use controls
- Strong, durable cart is easy to maneuver
- Can be used for aluminum repair, bumper repair or dent removal
- 6 kw of power



## REVO HANDHELD

THE ULTIMATE TOOL FOR BODY REPAIRS.

REVO Handheld is lightweight and features an ergonomic handle, making it the ideal tool for rapidly curing filler, primer and clear coat. There are no special power requirements, the unit simply connects to any 110-volt outlet. Extended panels stay cool to the touch and allow the unit to be placed on the ground without damaging the lamp or burning the floor.

- Lightweight, easy to control
- No warm up period; just switch on and start using
- Can be used in a wide variety of applications – including aluminum repair, bumper repair, dent removal, softening glass seals, and removing emblems and adhesives



# ADVANCECURE® SYSTEMS

## CUT DRYING TIMES IN HALF

Designed to help collision repair centers be more productive, efficient and profitable, the AdvanceCure Accelerated Airflow System from Global Finishing Solutions® (GFS) greatly reduces the amount of time needed to dry any type of base coat – be it waterborne or solvent-based.

As warm air rises in a paint booth, the surface temperature of the vehicle can vary by 15 degrees Fahrenheit from top to bottom. This can pose a challenge for achieving an even temperature of 140 degrees Fahrenheit over the entire surface of a vehicle. In a typical downdraft paint booth, this process can take up to 20 minutes. With AdvanceCure, this time can be cut in half to about eight minutes.

AdvanceCure distributes heat more evenly throughout the booth and over the vehicle. By reducing the amount of time required for each paint job and promoting an even cure in less time, AdvanceCure helps put more jobs through your shop.

## HOW ADVANCECURE® WORKS

When a paint booth is in spray mode, a layer of slow-moving air – known as boundary air – forms on the vehicle surface. This boundary air traps solvents and prevents the heated air from reaching the vehicle surface during cure mode, therefore slowing down the paint drying process.

The key to AdvanceCure's amazing results is the controlled turbulent airflow it creates on the surface of the vehicle. This significantly improves the transfer of heat from the air to the painted panels, and provides a more even heat distribution over the entire vehicle. The result is drastically reduced drying times and better paint finishes.

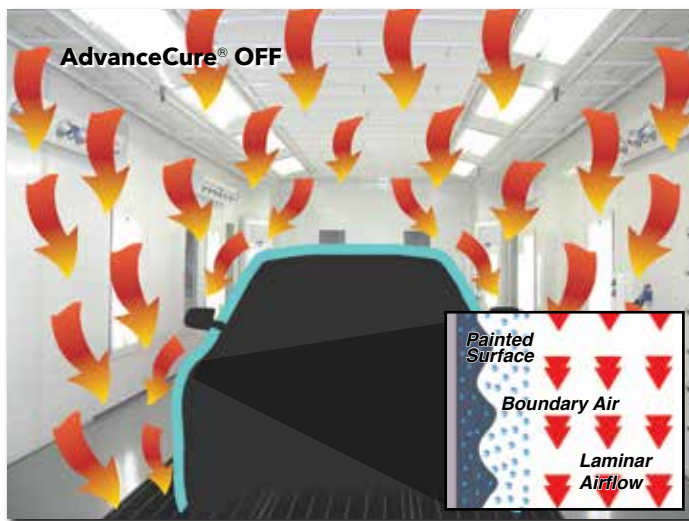

## CONTAMINANT-FREE AIRFLOW

GFS' AdvanceCure System provides superior contamination control to keep dirt and dust out of your paint finish. Before air exits the AdvanceCure module and enters the paint booth, it is filtered three times – through the booth intake pre-filter, ceiling filter and filter within the module. This supplies the paint booth with contaminant-free airflow.

## FULL VEHICLE OR SPOT PAINTING

The unique control system on GFS' AdvanceCure gives you complete control over each individual module, making it just as effective for spot painting a single panel as it is for painting the entire vehicle. By turning on only the modules that you need for the job, you will also reduce energy costs.



# ADVANCECURE® SYSTEMS

## CONTINUOUSLY IMPROVED

Dedicated to continuous improvement and developing industry-leading products, GFS' AdvanceCure System has seen significant improvements since it was first introduced in 1998 – the first of its kind on the market. Today's AdvanceCure System is far more efficient than previous models and can be integrated into virtually any spray booth or prep environment.



### NOZZLE SYSTEM

The standard AdvanceCure System features multiple independently adjustable air nozzles on each module. The nozzles can be positioned at problem areas or at regular intervals around the booth to improve the overall booth airflow. The optional laser-aiming device makes it easy to pinpoint specific areas of the painted surface.



### BLADE SYSTEM

The Blade option for GFS' AdvanceCure System improves upon the class-leading performance of the standard nozzle system. Tested by paint companies, AdvanceCure Blade® provides premium performance and reduced maintenance, with no need to move or clean nozzles. The exclusive air-knife design enables the precise direction of air through small slits in the module. The Blade option can be added to most I-Series horizontal AdvanceCure models.

## Iseries

### CABIN-INTEGRATED SYSTEMS FOR NEWER MODEL GFS BOOTHS

GFS' AdvanceCure I-Series models are designed to seamlessly integrate into GFS automotive paint booths, making the best use of the booth's space and resources. Our sleekest AdvanceCure I-Series model on Ultra booths features motors that are hidden in the plenum.

All new standard GFS Ultra® Paint Booths and CTOFs, and most Performer® Paint Booths are designed to support the AdvanceCure I-Series so that you can easily add the system at any time.



Examples of AdvanceCure I-Series

## Rseries

### RETROFIT SYSTEMS DESIGNED TO FIT ANY EXISTING PAINT BOOTH

R-Series AdvanceCure Systems can be installed in virtually any model or brand of paint booth or prep environment. The AdvanceCure R-Series comes in multiple designs to accommodate various booth styles and sizes. Modules can be placed in the corner or on the sidewall of the booth, and feature either fully integrated or remote blowers.



Examples of AdvanceCure R-Series

# CONTROL PANELS

GFS offers several control panels for operating auto refinish spray booths. From the fully loaded LOGIC 4 to the more simplistic Engage, there's a control system for everyone.

## LOGIC 4

Standard on all Ultra XP1 booths, the LOGIC 4 control panel is the most advanced and user-programmable spray booth control system on the market today. This top-of-the-line control panel allows you complete control over the booth and the ability to easily switch from waterborne to solvent base.

### FEATURES

- 10-inch color touch screen interface
- Controls for AdvanceCure, SmartCure, SmartFlash, filter monitoring and economy mode
- Ability to turn individual AdvanceCure blowers on and off during flash and cure modes
- Three SmartFlash profiles with three programmable segments each
- Six SmartCure profiles (three waterborne, three solvent base) with five programmable segments each
- Self diagnostics to help you easily identify service issues



## LOGIC 3

Designed with everything you need to control your booth, the LOGIC 3 control panel is an impressive yet simple control system. The LOGIC 3 has many of the same user-programmable features as the LOGIC 4, but on a smaller, streamlined user interface.

### FEATURES

- 6-inch monochrome touch screen interface
- Controls for SmartCure, SmartFlash and economy mode
- Three SmartFlash profiles with three programmable segments each
- Three SmartCure profiles with three programmable segments each
- Self diagnostics to help you easily identify service issues



## ENGAGE®

The Engage control panel features a simplified, easy-to-use touch screen interface with enhancements such as improved temperature and pressure control and alarm tracking for better, more reliable booth performance.

### FEATURES

- 4-inch color touch screen interface
- Spray, cure and flash cycles
- Enhanced temperature and pressure controls
- Alarm tracking with date and time stamps for improved troubleshooting
- Self diagnostics to help you easily identify service issues



# CONTROL FEATURES

## SMART TECHNOLOGY

No two paints are alike. Every kind of paint requires a specific setting for proper application and curing. Smart Technology, integrated into all LOGIC control panels, takes the guesswork out of operating a paint booth.

### FEATURES

- Three programmable options to control time, temperature, AdvanceCure towers and dampers
- Automated controls for reliable and predictable results
- Adjustable for any type of coating

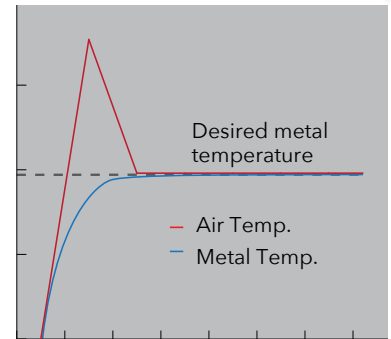

## SMARTFLASH

Before a second coat can be applied, the base coat must dry to a certain temperature. SmartFlash maintains temperature while decreasing drying time between coat applications. By recirculating 90 percent of the booth air, energy costs are significantly reduced.

## SMARTCURE®

Whereas conventional cure modes use the same air temperature throughout the cure cycle, SmartCure reduces air temperature once the metal reaches its desired temperature. Thus, energy costs are reduced by up to 25 percent in cure mode. Average cost savings with SmartCure is \$1.60 per cycle.\*

\*Savings based on a SmartCure cycle that includes a 6-minute cure at 180 degrees, 18-minute cure at 140 degrees and 3-minute cool down at ambient.

## VFD

Two variable frequency drives (VFDs) provide energy-saving smooth motor starts and facilitate the operation of the booth in economy mode.

## SELF-DIAGNOSTICS AND ALARMS

At the touch of a button, the LOGIC panel displays all PLC inputs and outputs, so the technician can easily monitor parameters of speed, temperature, pressure and other pertinent information regarding the operation of the booth.

When a failure occurs, the LOGIC control panel will automatically shut down the booth and display all errors on the screen. This will allow the technician to quickly pinpoint the error and make necessary repairs, reducing your overall downtime.

## ECONOMY MODE

Economy mode is an energy-saving feature that can save you up to 60 percent in electricity and 75 percent in fuel, when compared to the same booth running at full capacity for the same period of time. After a pre-set time delay, the control panel will automatically switch to economy mode when the operator in the booth has stopped spraying, reducing the overall airflow by up to 50 percent and maintaining the same temperature in the paint environment.



# GFS AIRFLOW

GFS paint booths are designed for the most consistent airflow through the booth. The majority of our auto refinish booths feature a 2-foot-high ceiling-over-plenum design. The 2-foot height provides more room for building sufficient air volume. A full-width ceiling plenum allows for less static pressure and even air distribution from the plenum to the cabin.

It is important to provide a clean even flow of air around the vehicle or parts being painted. A large plenum builds sufficient air volume necessary to create the even linear, plenum-to-pit airflow.

Before air reaches the plenum, it passes through a diffuser. The diffuser directs air leaving the heater, and creates even airflow throughout the plenum.

Air must be drawn evenly around the vehicle, and have the ability to be balanced. This is accomplished with pit pans – metal plates with various size holes – that are placed under the filter media to balance the airflow from end to end.

## CONTROLLED AIRFLOW CEILING

A key feature of GFS' premium spray booths is the Controlled Airflow Ceiling. This patented, exclusive ceiling design was engineered to maximize the effectiveness of downdraft airflow models.

The main airflow zone creates a protective envelope of air around the vehicle, while secondary airflow zones prevent overspray from collecting on the booth walls, and keep contaminants away from the paint job. In between these airflow zones are strategically placed ceiling lights. These color-corrected lights are located directly above the sides of the car for optimal illumination.

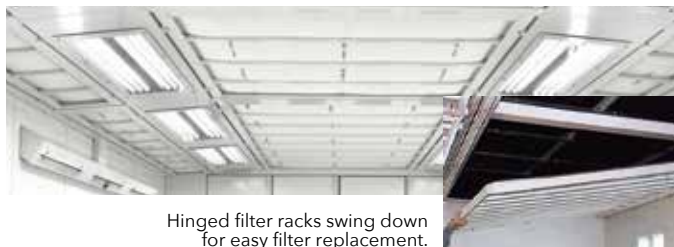

## HIGH-PERFORMANCE AIRFLOW CEILING

A classic design, the High-Performance Airflow Ceiling is simple in its construction and concept, yet yields impressive performance. The full-filtered ceiling provides excellent air filtration and contamination control, and the integrated hip-style ceiling lights illuminate where you need it most.



# EXHAUST PITS

## BREAKING DOWN THE GFS PIT

GFS' downdraft auto refinish booths feature a four-part pit system, designed to evenly draw air out of the booth while capturing and holding paint overspray. A key component of this pit system is the diffusion trays. With holes of varying sizes, these trays allow more air to flow through the exhaust pit at specific parts of the booth, based on the location of the heater unit.

Exhaust filters are suspended in the pit, held up by wire grids, for maximum filter utilization and balanced airflow. Heavy-duty steel grating allows the painter to walk on top of the pit.

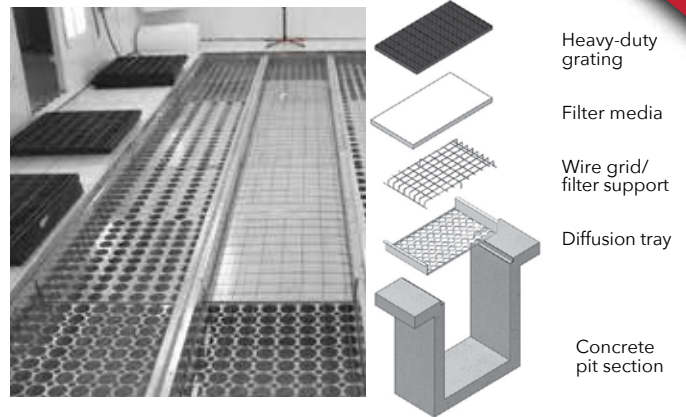

## PIT OPTIONS

### SINGLE-ROW PIT

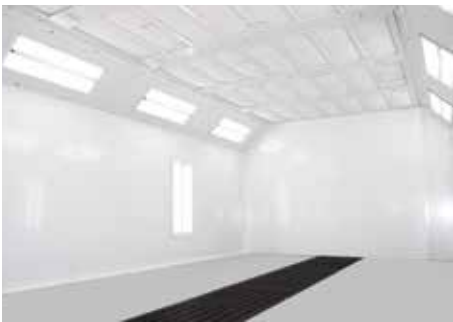

### TWO-ROW PIT

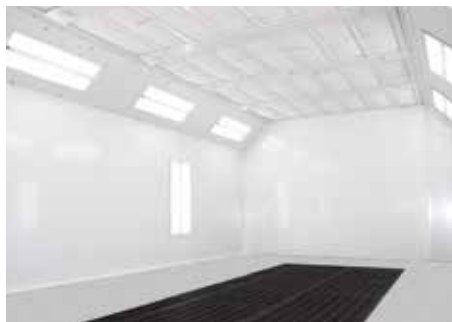

### THREE-ROW PIT



## FULL-LENGTH PIT

As opposed to our competitors, GFS' auto refinish booth pits run nearly the entire length of the booth. The longer pit means that airflow envelops the front and back of the car better. This allows for more even airflow and less overspray ending up on the floor of the booth.



## RAISED BASEMENTS

When a traditional pit is not possible, raised basements can be added to a downdraft booth to facilitate downdraft airflow. Raised basements also allow for a booth to be moved more easily to a different location, and can reduce construction time.



## GRATE LIFTING TOOL

This tool is designed to assist in raising exhaust pit grates when filters need replacing. Made of heavy-duty metal, this tool allows you to lift and maneuver heavy grates without straining your back or pinching your fingers in between grates.



# BOOTH LIGHTING

## NO SHADOWS

Shadows can interfere with a painter's depth perception, making it much more difficult to apply the perfect finish on a vehicle. Horizontal sidewall lighting, commonly found in automotive paint booths, cast constant shadows on the vehicle as you spray.

To combat this issue, GFS has designed all of our automotive paint booths with vertical sidewall lights and either angled ceiling or hip lights. The combination of the two allows the painter to move freely around the vehicle with less light interaction. This creates a virtually shadow-free environment, perfect for the precise application of paint.

## LIGHTING FEATURES

- Four- or six-tube, 48-inch, inside access fixtures
- T8 ballast provides greater energy savings
- LED lamps
- 32-watt, dual voltage (120/277)
- ETL and ETL-C listed
- Interlock switch to disable painting operations when light access door is opened.
- Easy tube replacement and maintenance



## LED LAMPS

Standard on all GFS automotive paint booths and prep stations, T8 LED lamps provide significant energy savings, a whiter light inside the working area and fewer surface reflections. LED lamps also last longer than traditional fluorescent bulbs, reducing costs incurred by frequent bulb replacements.



# BOOTH ACCESSORIES

## BOOTH SHIELD® STRIPPABLE COATING

Booth Shield coatings provide superior protection and create a safer spraying environment. The coatings can be applied quickly and easily to your booth for instant brightening and surface protection. The film can be removed easily, without damaging the underlying substrate.



## GFS WAVE®

GFS Wave is an economical, high-performance exhaust filtration solution for businesses of all sizes and production levels. The convoluted “wave” design of GFS Wave filters increases surface area for great depth loading and holding capacity. By effectively capturing and retaining overspray, GFS Wave filters minimize paint runoff. This results in less cleanup of the paint booth floor and quicker, more efficient filter changes.



## ROLLSEAL® DOORS

With their heavy-duty fabric, RollSeal Automated Doors can be installed at the paint booth entrance and at the exit for drive-thru booths as a durable, low-maintenance solution to eliminate the space needed for traditional wing or swing-style doors.

RollSeal Doors provide an airtight seal and superior contamination control to keep overspray out of paint jobs. In addition to product entry and exit, RollSeal Door can be used in sideload booth systems to control contamination and airflow between bays.



## GFS POLY™

The premium exhaust filter solution for high-volume shops, GFS Poly features an exceptional holding capacity and efficiency rating for long-lasting performance, reduced costs and increased paint shop productivity. The unique two-layer construction reduces face loading for long-lasting performance and less filter changes, significantly increasing the productivity in your paint shop and reducing costs incurred from frequent filter replacement.



[globalfinishing.com](http://globalfinishing.com)

[autorefinishsales@globalfinishing.com](mailto:autorefinishsales@globalfinishing.com)

877-658-7900

